

**TOP VIEW**  
SCALE: 3/8"=1'-0"

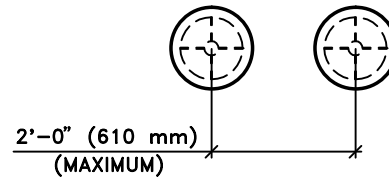

**TOP VIEW**  
SCALE: 3/8"=1'-0"

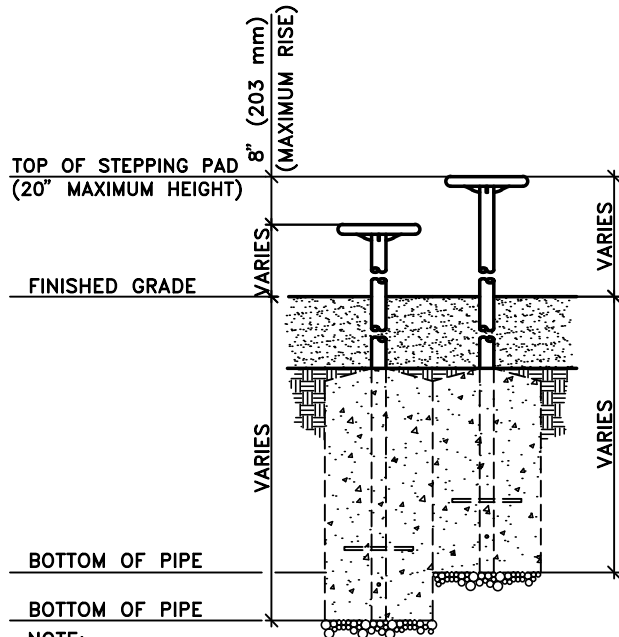

**NOTE:**  
CONCRETE FOOTING AND NO.4 REBAR (BY OTHERS) PER LOCAL SOIL CONDITIONS, CONSULT PROJECT ENGINEER FOR EXACT REQUIREMENTS.

**FRONT VIEW**  
SCALE: 3/8"=1'-0"

TYPICAL DETAIL AT 2-5 YEARS OF AGE

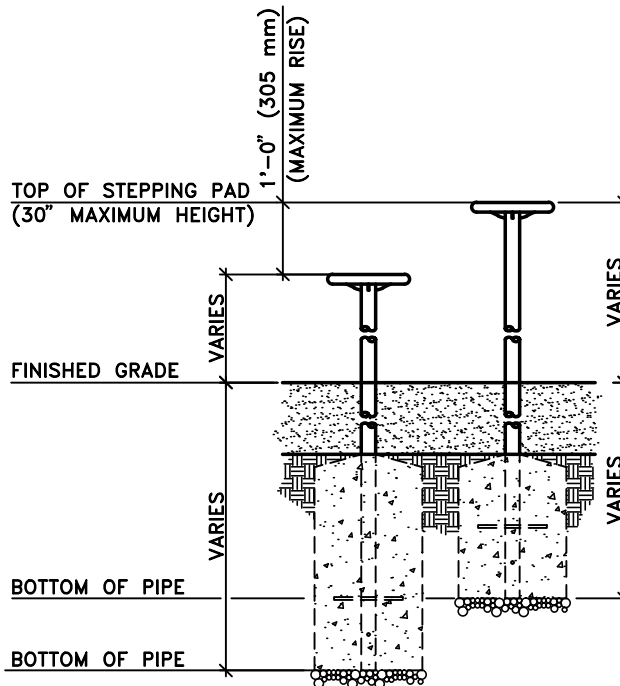

**NOTE:**  
CONCRETE FOOTING AND NO.4 REBAR (BY OTHERS) PER LOCAL SOIL CONDITIONS, CONSULT PROJECT ENGINEER FOR EXACT REQUIREMENTS.

**FRONT VIEW**  
SCALE: 3/8"=1'-0"

TYPICAL DETAIL AT 5-12 YEARS OF AGE

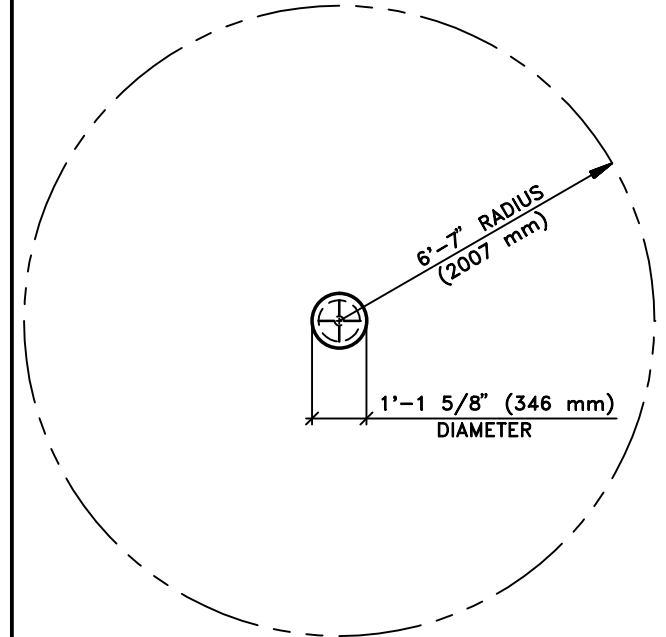

**PLAN VIEW WITH USE ZONE**  
SCALE: 1/4"=1'-0"

EQUIPMENT SPACE AND MINIMUM SAFE USE ZONE: VARIES

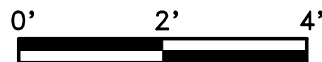

This drawing reveals the copyrighted intellectual property of Columbia Cascade Company. Not for use by others without our express, written authorization.

Authorization for use is hereby granted to architects, landscape architects and similar design professionals solely for the purpose of specifying TimberForm products.



|       |              |          |
|-------|--------------|----------|
| Scale | Drawn by: AT | 07-26-12 |
| NOTED | Ck'd by: CL  | 07-26-22 |



**COLUMBIA CASCADE COMPANY**

Makers of TimberForm®, PipeLine®, RePlay®, TimberForm®-2, InterPlay®, CycLoops® and CycLocker® Products.

1300 S.W. Sixth Avenue, Suite 310 Telephone 503/223-1157  
Portland, Oregon 97201-3464 Facsimile 503/223-4530  
U.S.A.

WWW.TIMBERFORM.COM

Title:  
SEPARATES  
MODEL NO. 1602-01-00  
STEPPING PAD

Drawing No.  
W-1602-01-00

Sheet  
1 of 1