

**TOP VIEW**  
SCALE: 1/4"=1'-0"

4'-0" (1219 mm)  
TOP OF POST

0'-0" (0 mm)  
FINISHED GRADE

-(3'-0") BOTTOM OF POST  
-(914 mm)

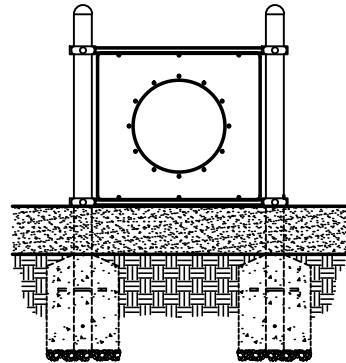
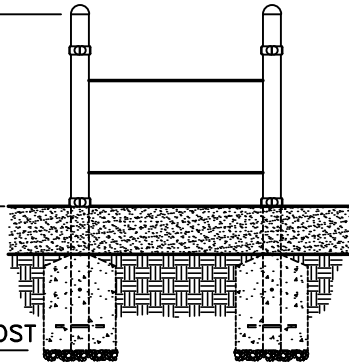

**SIDE VIEW**  
SCALE: 1/4"=1'-0"

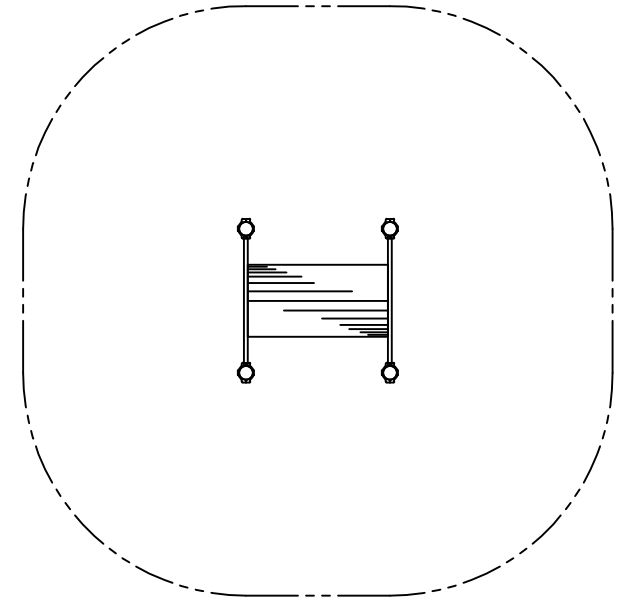

**PLAN VIEW WITH USE ZONE**  
SCALE: 3/16"=1'-0"

EQUIPMENT ONLY:  
5' x 5' (1.6m x 1.6m)  
MINIMUM SAFE USE ZONE:  
17' x 17' (5.2m x 5.2m)

**NOTE:**  
CONCRETE FOOTING AND NO. 4 REBAR (BY OTHERS) PER LOCAL SOIL CONDITIONS. CONSULT PROJECT ENGINEER FOR EXACT REQUIREMENTS.

**FRONT VIEW**  
SCALE: 1/4"=1'-0"

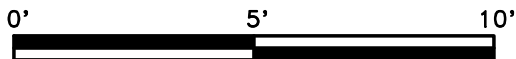

This drawing reveals the copyrighted intellectual property of Columbia Cascade Company. Not for use by others without our express, written authorization.

Authorization for use is hereby granted to architects, landscape architects and similar design professionals solely for the purpose of specifying TimberForm products.



Scale	Drawn by: AT	07-26-12
NOTED	Ck'd by: CL	07-26-12



**COLUMBIA CASCADE COMPANY**

Makers of TimberForm®, PipeLine®, RePlay®, TimberForm®-2, InterPlay®, CycLoops® and CycLocker® Products.

1300 S.W. Sixth Avenue, Suite 310 Telephone 503/223-1157  
Portland, Oregon 97201-3464 Facsimile 503/223-4530  
U.S.A.

WWW.TIMBERFORM.COM

Title:  
SEPARATES  
MODEL NO. 1918-00-03-PI  
TUNNEL CRAWL,  
STAINLESS STEEL WITH  
METAL PANELS

Drawing No. W-1918-00-03-PI Sheet 1 of 1