

TOP VIEW
SCALE: 3/8"=1'-0"

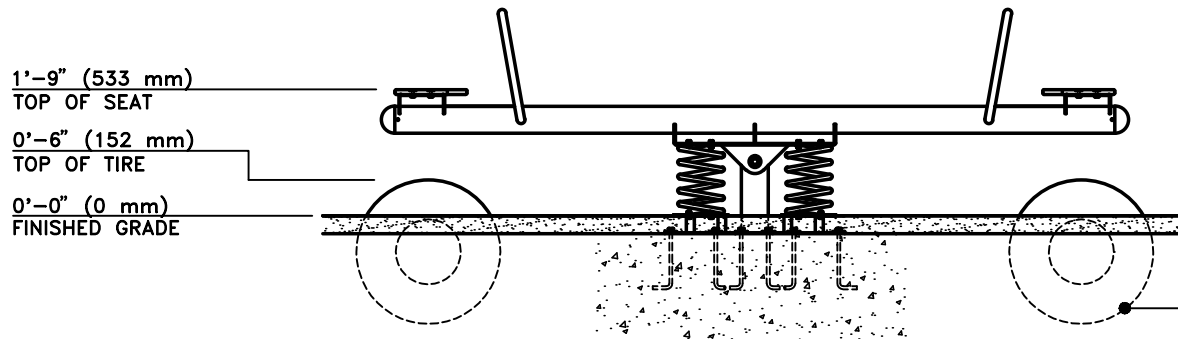

FRONT VIEW
SCALE: 3/8"=1'-0"

USED TIRE SHOCK ABSORBER
(BY OTHERS, TYPICAL-2)
WARRANTY IS VOID IF OWNER
FAILS TO INSTALL AND MAINTAIN

NOTE:
CONCRETE FOOTING (BY OTHERS).
CONSULT PROJECT ENGINEER FOR
EXACT REQUIREMENTS. THREE 5/8"
(16 mm) DIAMETER HOLES PROVIDED
IN PEDESTAL ASSEMBLIES FOR
ANCHORING DEVICES (BY OTHERS).

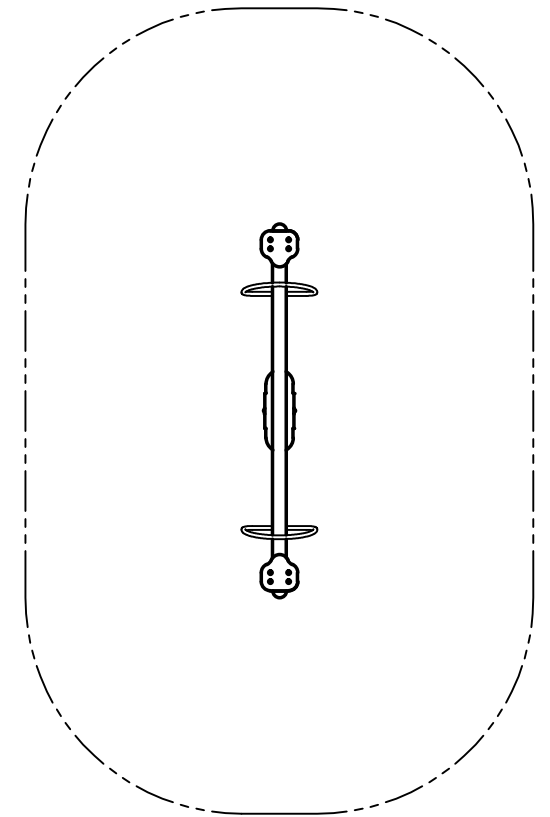

PLAN VIEW WITH USE ZONE
SCALE: 3/16"=1'-0"

SPRING RIDER, EQUIPMENT ONLY:
3' x 11' (1.0m x 3.4m)

MINIMUM SAFE USE ZONE:
15' x 23' (4.6m x 7.1m)

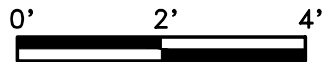

This drawing reveals the copyrighted intellectual property of Columbia Cascade Company. Not for use by others without our express, written authorization.
Authorization for use is hereby granted to architects, landscape architects and similar design professionals solely for the purpose of specifying TimberForm products.



Scale	Drawn by: AT	07-26-12
NOTED	Ck'd by: CL	07-26-12



COLUMBIA CASCADE COMPANY

Makers of TimberForm®, PipeLine®,
RePlay®, TimberForm®-2, InterPlay®,
CycLoops® and CycLocker® Products.

1300 S.W. Sixth Avenue, Suite 310 Telephone 503/223-1157
Portland, Oregon 97201-3464 Facsimile 503/223-4530
U.S.A.

WWW.TIMBERFORM.COM

Title:
SEPARATES
MODEL NO. 3870-2-P
SPRING RIDER SEE-SAW
(PEDESTAL)

Drawing No.
W-3870-2-P

Sheet
1 of 1